

Simultaneous Heating&Cooling Output PID Temperature Controllers

TK Series

INSTRUCTION MANUAL

TCD210240AD	Autonics
-------------	-----------------

Thank you for choosing our Autonics product.

Read and understand the instruction manual and manual thoroughly before using the product.

For your safety, read and follow the below safety considerations before using.

For your safety, read and follow the considerations written in the instruction manual, other manuals and Autonics website.

Keep this instruction manual in a place where you can find easily.

The specifications, dimensions, etc are subject to change without notice for product improvement Some models may be discontinued without notice.

Follow Autonics website for the latest information.

Safety Considerations
<ul style="list-style-type: none">Observe all ‘Safety Considerations’ for safe and proper operation to avoid hazards. ▲ symbol indicates caution due to special circumstances in which hazards may occur.
<p>▲ Warning Failure to follow instructions may result in serious injury or death</p>

01. Fail-safe device must be installed when using the unit with machinery that may cause serious injury or substantial economic loss.(e.g. nuclear power control, medical equipment, ships, vehicles, railways, aircraft, combustion apparatus, safety equipment, crime/disaster prevention devices, etc.) Failure to follow this instruction may result in personal injury, economic loss or fire.

02. Do not use the unit in the place where flammable/explosive/corrosive gas, high humidity, direct sunlight, radiant heat, vibration, impact or salinity may be present. Failure to follow this instruction may result in explosion or fire.

03. Install on a device panel to use. Failure to follow this instruction may result in electric shock.

04. Do not connect, repair, or inspect the unit while connected to a power source. Failure to follow this instruction may result in fire or electric shock.

05. Check ‘Connections’ before wiring. Failure to follow this instruction may result in fire.

06. Do not disassemble or modify the unit. Failure to follow this instruction may result in fire or electric shock.

<p>▲ Caution Failure to follow instructions may result in injury or product damage</p>

01. When connecting the power input and relay output, use AWG 20 (0.50 mm²) cable or over, and tighten the terminal screw with a tightening torque of 0.74 to 0.90 N m.

When connecting the sensor input and communication cable without dedicated cable, use AWG 28 to 16 cable and tighten the terminal screw with a tightening torque of 0.74 to 0.90 N m.

Failure to follow this instruction may result in fire or malfunction due to contact failure.

02. Use the unit within the rated specifications.

Failure to follow this instruction may result in fire or product damage

03. Use a dry cloth to clean the unit, and do not use water or organic solvent. Failure to follow this instruction may result in fire or electric shock.

04. Keep the product away from metal chip, dust, and wire residue which flow into the unit.

Failure to follow this instruction may result in fire or product damage.

Cautions during Use
<ul style="list-style-type: none">Follow instructions in ‘Cautions during Use’. Otherwise, it may cause unexpected accidents. Check the polarity of the terminals before wiring the temperature sensor. For RTD temperature sensor, wire it as 3-wire type, using cables in same thickness and length. For thermocouple (TC) temperature sensor, use the designated compensation wire for extending wire. Keep away from high voltage lines or power lines to prevent inductive noise. In case installing power line and input signal line closely, use line filter or varistor at power line and shielded wire at input signal line. Do not use near the equipment which generates strong magnetic force or high frequency noise. Do not apply excessive power when connecting or disconnecting the connectors of the product. Install a power switch or circuit breaker in the easily accessible place for supplying or disconnecting the power. Do not use the unit for other purpose (e.g. voltmeter, ammeter), but temperature controller. When changing the input sensor, turn off the power first before changing. After changing the input sensor, modify the value of the corresponding parameter.

- 24 VAC~, 24-48 VDC= power supply should be insulated and limited voltage/current or Class 2, SELV power supply device.
- Do not overlapping communication line and power line. Use twisted pair wire for communication line and connect ferrite bead at each end of line to reduce the effect of external noise.
- Make a required space around the unit for radiation of heat. For accurate temperature measurement, warm up the unit over 20 min after turning on the power.
- Make sure that power supply voltage reaches to the rated voltage within 2 sec after supplying power.
- Do not wire to terminals which are not used.
- This unit may be used in the following environments.
 - Indoors (in the environment condition rated in ‘Specifications’)
 - Altitude Max. 2,000 m
 - Pollution degree 2
 - Installation category II

Ordering Information

This is only for reference, the actual product does not support all combinations. For selecting the specified model, follow the Autonics website .

T	K	①	②	-	③	④	⑤	⑥
----------	----------	----------	----------	----------	----------	----------	----------	----------

① Digit	④ Power supply
4: 4 digit	2: 24 VAC~ 50/60 Hz, 24-48 VDC=
	4: 100-240 VAC~ 50/60 Hz
② Size	⑤ OUT1 Control output
N: DIN W 48 × H 24 mm	R: Relay
SP: DIN W 48 × H 48 mm (11 pin plug type)	S: SSR drive
S: DIN W 48 × H 48 mm	C: Selectable current or SSR drive output
M: DIN W 72 × H 72 mm	
W: DIN W 96 × H 48 mm	
H: DIN W 48 × H 96 mm	
L: DIN W 96 × H 96 mm	

③ Option in/output	⑥ OUT2 Control output
Size: N	N: Normal type
PN OUT2	[No OUT2 (Heating or Cooling)]
1	R: Heating & Cooling type [Relay output] ⁰¹⁾
2	C: Heating & Cooling type [Selectable current or SSR drive output] ⁰⁴⁾
D	
R	
T	

Size: SP
PN Function
1 Alarm 1

Size: S, M, W, H, L
PN Function
1 Alarm 1
2 Alarm 1 + Alarm output 2
R Alarm 1 + Transmission output
T Alarm 1 + RS485 communication
A Alarm 1 + Alarm 2 + Transmission output
B Alarm 1 + Alarm 2 + RS485 communication
D Alarm 1 + Alarm 2 + Digital input 1/2 ⁰²⁾

01) The CT input model of TK4N can be selected only in the normal type model with alarm output 1. (except TK4SP)

02) Only for TK4S-D, OUT2 output terminal is used as DI-2 input terminal.

03) When operating mode is heating or cooling control, OUT2 can be used as alarm output 3 (except TK4N).

04) When operating mode is heating or cooling control, OUT2 can be used as transmission output 2.

Product Components
<ul style="list-style-type: none">Product (+ bracket) Instruction manual [TK4N] Terminal protection cover × 1







Manual
<p>For proper use of the product, refer to the manuals and be sure to follow the safety considerations in the manuals. Download the manuals from the Autonics website.</p>

Software
<p>Download the installation file and the manuals from the Autonics website.</p>
<p>■ DAQMaster</p> <p>DAQMaster is comprehensive device management program. It is available for parameter setting, monitoring.</p>

Sold Separately
<ul style="list-style-type: none">Current transformer (CT) 11-pin controller socket: PG-11, PS-11 (N) Terminal protection cover: RSA / RMA / RHA / RLA-Cover Communication Converter: SCM-US / SCM-38I / SCM-US48I / SCM-WF48

Specifications																																			
<table> <tbody><tr> <th>Series</th> <th>TK4N</th> <th>TK4SP</th> <th>TK4S</th> <th>TK4M</th> </tr> <tr> <th>Power supply</th> <td>AC type</td> <td colspan="3">100 - 240 VAC~ 50/60 Hz</td> </tr> <tr> <th></th> <td>AC/DC type</td> <td>-</td> <td colspan="2">24 VAC~ 50/60 Hz, 24-48 VDC=</td> </tr> <tr> <th>Permissible voltage range</th> <td colspan="4">90 to 110 % of rated voltage</td> </tr> <tr> <th>Power consumption</th> <td>AC type</td> <td>≤ 6 VA</td> <td colspan="2">≤ 8 VA</td> </tr> <tr> <th></th> <td>AC/DC type</td> <td>-</td> <td colspan="2">AC: ≤ 8 VA, DC ≤ 5W</td> </tr> <tr> <th>Unit weight (packaged)</th> <td>≈ 70 g (≈ 140 g)</td> <td>≈ 85 g (≈ 130 g)</td> <td>≈ 105 g (≈ 150 g)</td> <td>≈ 140 g (≈ 210 g)</td> </tr> </tbody></table>	Series	TK4N	TK4SP	TK4S	TK4M	Power supply	AC type	100 - 240 VAC~ 50/60 Hz				AC/DC type	-	24 VAC~ 50/60 Hz, 24-48 VDC=		Permissible voltage range	90 to 110 % of rated voltage				Power consumption	AC type	≤ 6 VA	≤ 8 VA			AC/DC type	-	AC: ≤ 8 VA, DC ≤ 5W		Unit weight (packaged)	≈ 70 g (≈ 140 g)	≈ 85 g (≈ 130 g)	≈ 105 g (≈ 150 g)	≈ 140 g (≈ 210 g)
Series	TK4N	TK4SP	TK4S	TK4M																															
Power supply	AC type	100 - 240 VAC~ 50/60 Hz																																	
	AC/DC type	-	24 VAC~ 50/60 Hz, 24-48 VDC=																																
Permissible voltage range	90 to 110 % of rated voltage																																		
Power consumption	AC type	≤ 6 VA	≤ 8 VA																																
	AC/DC type	-	AC: ≤ 8 VA, DC ≤ 5W																																
Unit weight (packaged)	≈ 70 g (≈ 140 g)	≈ 85 g (≈ 130 g)	≈ 105 g (≈ 150 g)	≈ 140 g (≈ 210 g)																															

Series	TK4W	TK4H	TK4L
Power supply	AC type	100 - 240 VAC~ 50/60 Hz	
	AC/DC type	24 VAC~ 50/60 Hz, 24-48 VDC=	
Permissible voltage range	90 to 110 % of rated voltage		
Power consumption	AC type	≤ 8 VA	
	AC/DC type	AC: ≤ 8 VA, DC ≤ 5W	
Unit weight (packaged)	≈ 141 g (≈ 211 g)	≈ 141 g (≈ 211 g)	≈ 198 g (≈ 294 g)

Sampling period	50 ms
Input specification	Refer to 'Input Type and Using Range'
Option input	CT input <ul style="list-style-type: none">0.0-50.0 A (primary current measurement range) CT ratio: 1/1,000 Measurement accuracy: ±5% F.S. ±1digit <p>Digital input</p> <ul style="list-style-type: none">Contact - ON: ≤ 2 kΩ, OFF: ≥ 90 kΩ Non contact - residual voltage ≤ 1.0 V, leakage current ≤ 0.1 mA Outflow current: ≈ 0.5 mA per input
Control output	Relay <p>250 VAC~ 3 A, 30 VDC= 3 A 1a</p> <p>SSR <p>11 VDC= ±2 V, ≤ 20 mA</p> <p>Current <p>DC 4-20 mA or DC 0-20 mA (parameter), Load resistance: ≤ 500 Ω</p></p></p>
Alarm output	Relay <p>AL1, AL2: 250 VAC~ 3 A 1a</p> <p>TK4N AL2: 250 VAC~ 0.5 A 1a (≤ 125 VA)</p>
Option output	Transmission <p>DC 4 - 20 mA (Load resistance: ≤ 500 Ω, Output accuracy: ±0.3% F.S.)</p> <p>RS485 comm. <p>Modbus RTU</p></p>
Display type	7 segment (red, green, yellow), LED type
Control type	Heating, Cooling, Heating & Cooling <p>ON/OFF, P, PI, PD, PID Control</p>
Hysteresis	<ul style="list-style-type: none">Thermocouple, RTD: 1 to 100 (0.1 to 100.0) °C/°F Analog: 1 to 100 digit
Proportional band (P)	0.1 to 999.9 °C/°F (0.1 to 999.9%)
Integral time (I)	0 to 9,999 sec
Derivative time (D)	0 to 9,999 sec
Control cycle (T)	<ul style="list-style-type: none">Relay output, SSR drive output: 0.1 to 120.0 sec Selectable current or SSR drive output: 1.0 to 120.0 sec
Manual reset	0.0 to 100.0%
Relay life cycle	<p>Mechanical <p>OUT1/2: ≥ 5,000,000 operations</p> <p>AL1/2: ≥ 20,000,000 operations (TK4H/W/L: ≥ 5,000,000 operations)</p></p> <p>Electrical <p>≥ 100,000 operations</p></p>
Dielectric strength	Dependent on the power supply
AC voltage type	Between the charging part and the case: 3,000 VAC ~ 50/60 Hz for 1 minute
AC / DC voltage type	Between the charging part and the case: 2,000 VAC ~ 50/60 Hz for 1 minute
Vibration	0.75 mm amplitude at frequency of 5 to 55 Hz in each X, Y, Z direction for 2 hours
Insulation resistance	≥ 100 M.Ω (500 VDC= megger)
Noise immunity	±2 kV square shaped noise by noise simulator (pulse width: 1 μs) <p>R-phase, S-phase</p>
Memory retention	≈ 10 years (non-volatile semiconductor memory type)
Ambient temperature	-10 to 50 °C, storage: -20 to 60 °C (no freezing or condensation)
Ambient humidity	35 to 85%RH, storage: 35 to 85%RH (no freezing or condensation)
Protection structure	IP65 (Front panel, IEC standards) <ul style="list-style-type: none">TK4SP: IP50 (Front panel, IEC standards)
Insulation type	Double insulation or reinforced insulation (mark:  , dielectric strength between the measuring input part and the power part: 2 kV)
Certification	    

Communication Interface	
<p>■ RS485</p>	
Comm. protocol	Modbus RTU
Connection type	RS485
Application standard	EIA RS485 compliance with
Maximum connection	31 units (address: 01 to 99)
Synchronous method	Asynchronous
Comm. Method	Two-wire half duplex
Comm. effective range	≤ 800 m
Comm. speed	2,400 / 4,800 / 9,600 (default) / 19,200 / 38,400 bps (parameter)
Response time	5 to 99 ms (default: 20 ms)
Start bit	1 bit (fixed)
Data bit	8 bit (fixed)
Parity bit	None (default), Odd, Even
Stop bit	1 bit, 2 bit (default)
EEPROM life cycle	≈ 1,000,000 operations (Erase / Write)

Input Type and Using Range					
<p>The setting range of some parameters is limited when using the decimal point display.</p>					
Input type	Decimal point	Display	Using range (°C)	Using range (°F)	
Thermo-couple	K (CA)	1	<i>℄ ℄ RH</i>	-200 to 1,350	-328 to 2,462
		0.1	<i>℄ ℄ RH</i>	-199.9 to 999.9	-199.9 to 999.9
	J (IC)	1	<i>℄ ℄ LH</i>	-200 to 800	-328 to 1,472
		0.1	<i>℄ ℄ LH</i>	-199.9 to 800.0	-199.9 to 999.9
	E (CR)	1	<i>℄ ℄ r-L</i>	-200 to 800	-328 to 1,472
		0.1	<i>℄ ℄ r-L</i>	-199.9 to 800.0	-199.9 to 999.9
	T (CC)	1	<i>℄ ℄ C-H</i>	-200 to 400	-328 to 752
		0.1	<i>℄ ℄ C-H</i>	-199.9 to 400.0	-199.9 to 752.0
	B (PR)	1	<i>℄ ℄ P r</i>	0 to 1,800	32 to 3,272
		1	<i>℄ ℄ P r</i>	0 to 1,750	32 to 3,182
	S (PR)	1	<i>℄ ℄ P r</i>	0 to 1,750	32 to 3,182
		1	<i>℄ ℄ n n</i>	-200 to 1,300	-328 to 2,372
C (TT) ⁰¹⁾	1	<i>℄ ℄ E E</i>	0 to 2,300	32 to 4,172	
	1	<i>℄ ℄ E E</i>	0 to 2,300	32 to 4,172	
L (IC)	1	<i>℄ ℄ C-H</i>	-200 to 900	-328 to 1,652	
	0.1	<i>℄ ℄ C-L</i>	-199.9 to 900.0	-199.9 to 999.9	
U (CC)	1	<i>℄ ℄ C-H</i>	-200 to 400	-328 to 752	
	0.1	<i>℄ ℄ C-L</i>	-199.9 to 400.0	-199.9 to 752.0	
RTD	Platinel II	1	<i>℄ ℄ I I</i>	0 to 1,390	32 to 2,534
		0.1	<i>℄ ℄ U S</i>	-199.9 to 200.0	-199.9 to 392.0
	Cu50 Ω	1	<i>℄ ℄ U S</i>	-199.9 to 200.0	-199.9 to 392.0
		0.1	<i>℄ ℄ U S</i>	-199.9 to 200.0	-199.9 to 392.0
	JPt100 Ω	1	<i>℄ ℄ P E-H</i>	-200 to 650	-328 to 1,202
		0.1	<i>℄ ℄ P E-L</i>	-199.9 to 650.0	-199.9 to 999.9
	DPT50 Ω	1	<i>℄ ℄ P E S</i>	-199.9 to 600.0	-199.9 to 999.9
		0.1	<i>℄ ℄ P E-L</i>	-200 to 650	-328 to 1,202
	DPT100 Ω	1	<i>℄ ℄ P E-L</i>	-199.9 to 650.0	-199.9 to 999.9
		0.1	<i>℄ ℄ P E-L</i>	-199.9 to 650.0	-199.9 to 999.9
	Nickel120 Ω	1	<i>℄ ℄ I E</i>	-80 to 200	-112 to 392
		0 to 10 V	-	<i>℄ ℄ U I</i>	0 to 10 V
0 to 5 V	-	<i>℄ ℄ U E</i>	0 to 5 V	0 to 5 V	
	1 to 5 V	-	<i>℄ ℄ U E</i>	1 to 5 V	
0 to 100 mV	-	<i>℄ ℄ U I</i>	0 to 100 mV	0 to 100 mV	
	0 to 20 mA	-	<i>℄ ℄ R I</i>	0 to 20 mA	
4 to 20 mA	-	<i>℄ ℄ R E</i>	4 to 20 mA	4 to 20 mA	

01) C (TT): Same as existing W5 (TT) type sensor

02) G (TT): Same as existing W (TT) type sensor

- Permissible line resistance per line: ≤ 5 Ω

Display accuracy		
Input type	Using temperature	Display accuracy
Thermo-couple	At room temperature (23°C ±5 °C)	(PV ±0.3% or ±1 °C higher one) ±1-digit <ul style="list-style-type: none">Thermocouple K, J, T, N, E below -100 °C and L, U, PLII, RTD Cu50 Ω, DPT50 Ω: (PV ±0.3% or ±2 °C higher one) ±1-digit Thermocouple C, G and R, S below 200 °C: (PV ±0.3% or ±3 °C higher one) ±1-digit Thermocouple B below 400 °C: There is no accuracy standards
	Out of room temperature range	(PV ±0.5% or ±2 °C higher one) ±1-digit <ul style="list-style-type: none">RTD Cu50 Ω, DPT50 Ω: (PV ±0.5% or ±3 °C higher one) ±1-digit Thermocouple R, S, B, C, G: (PV ±0.5% or ±5 °C higher one) ±1-digit Other sensors: ≤ ±5 °C (≤-100 °C)
Analog	At room temperature (23°C ±5 °C)	±0.3% F.S. ±1-digit
	Out of room temperature range	±0.5% F.S. ±1-digit

- In case of TK4SP Series, ±1 °C will be added to the degree standard.

Unit Descriptions

	<ol style="list-style-type: none">PV display part (Red) <ul style="list-style-type: none">Run mode: Displays PV (Present value). Setting mode: Displays parameter name. SV display part (Green) <ul style="list-style-type: none">Run mode: Displays SV (Setting value). Setting mode: Displays parameter setting value. Input key <table> <tbody><tr> <th>Display</th> <th>Name</th> </tr> <tr> <td>[A/M]</td> <td>Control switching key</td> </tr> <tr> <td>[MODE]</td> <td>Mode key</td> </tr> <tr> <td>[◀], [▼], [▲]</td> <td>Setting value control key</td> </tr> </tbody></table>	Display	Name	[A/M]	Control switching key	[MODE]	Mode key	[◀], [▼], [▲]	Setting value control key
Display	Name								
[A/M]	Control switching key								
[MODE]	Mode key								
[◀], [▼], [▲]	Setting value control key								

4. Indicator	Display	Name	Description
	°C, %, °F	Unit	Displays selected unit (parameter)
	AT	Auto tuning	Flashes during auto tuning every 1 sec
OUT1/2	Control output		Turns ON when the control output is ON <ul style="list-style-type: none">SSR output (cycle/phase control) MV over 5% ON Current output <p>Manual control: 0% OFF, over ON</p> <p>Auto control: below 2% OFF, over 3% ON</p>
		Alarm output	Turns ON when the alarm output is ON
MAN	Manual control		Turns ON during manual control
SV1/2/3	Multi SV		The SV indicator is ON which is currently displayed. (When using multi SV function)

- For the details about old model, refer to the user manual. Download the manuals from the Autonics website.



5



5. PC loader port: For connecting communication converter (SCM series).

Dimensions

- Unit: mm, For the detailed drawings, follow the Autonics website.
- Below is based on TK4S Series.

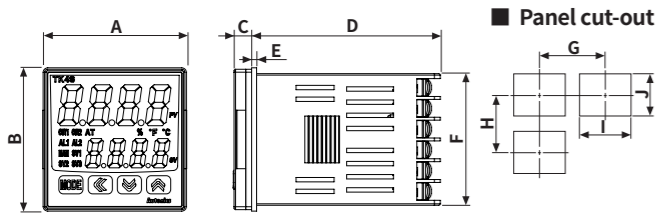

	Body					Panel cut-out				
	A	B	C	D	E	F	G	H	I	J
TK4N	48	24	3	91.8	-	21.8	≥ 55	≥ 37	45 ^{+0.6} ₀	22.2 ^{+0.3} ₀
TK4S	48	48	6	64.5	1.7	45	≥ 65	≥ 65	45 ^{+0.6} ₀	45 ^{+0.6} ₀
TK4SP	48	48	6	72.2	-	44.8	≥ 65	≥ 65	45 ^{+0.6} ₀	45 ^{+0.6} ₀
TK4M	72	72	6	64.5	1.7	67.5	≥ 90	≥ 90	68 ^{+0.7} ₀	68 ^{+0.7} ₀
TK4W	96	48	6	64.5	1.5	44.7	≥ 115	≥ 65	92 ^{+0.8} ₀	45 ^{+0.6} ₀
TK4H	48	96	6	64.5	1.5	91.5	≥ 65	≥ 115	45 ^{+0.6} ₀	92 ^{+0.8} ₀
TK4L	96	96	6	64.5	1.5	91.5	≥ 115	≥ 115	92 ^{+0.8} ₀	92 ^{+0.8} ₀

Bracket

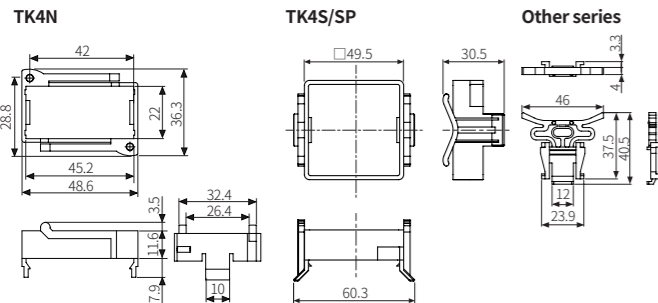

Terminal protection cover

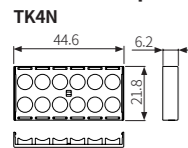

Installation Method

TK4N

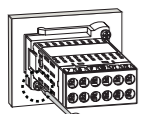

After mounting the product to panel with bracket, fasten the bolts by using screwdriver.

Other series

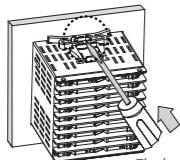

Insert the unit into a panel, fasten the bracket by pushing with a flathead screwdriver.

Errors

Display	Input	Description	Output	Troubleshooting
oPE n	Temperature sensor	Flashes at 0.5 sec interval when input sensor is disconnected or sensor is not connected.	'Sensor error, MV' parameter setting value	Check input sensor status.
	Analog	Flashes at 0.5 sec interval when input is over F.S. ±10%.	'Sensor error, MV' parameter setting value	Check analog input status.
HHHH	Temperature sensor	Flashes at 0.5 sec intervals if the input value is above the input range. ⁰¹⁾	Heating: 0%, Cooling: 100%	When input is within the rated input range, this display disappears.
	Analog	Flashes at 0.5 sec intervals if the input value is over 5 to 10% of high limit or low limit value.	Normal output	
LLLL	Temperature sensor	Flashes at 0.5 sec. intervals if the input value is below the input range. ⁰¹⁾	Heating: 100%, Cooling: 0%	When input is within the rated input range, this display disappears.
	Analog	Flashes at 0.5 sec intervals if the input value is over 5 to 10% of low limit or high limit value.	Normal output	
Err	Temperature sensor	Flashes at 0.5 sec intervals if there is error for setting and it returns to the error-before screen.	-	Check setting method.
	Analog	-	-	-

01) Be careful that when HHHH / L L L L error occurs, the control output may occur by recognizing the maximum or minimum input depending on the control type.

Connections

- Shaded terminals are standard model.
- Digital input is not electrically insulated from internal circuits, so it should be insulated when connecting other circuits.

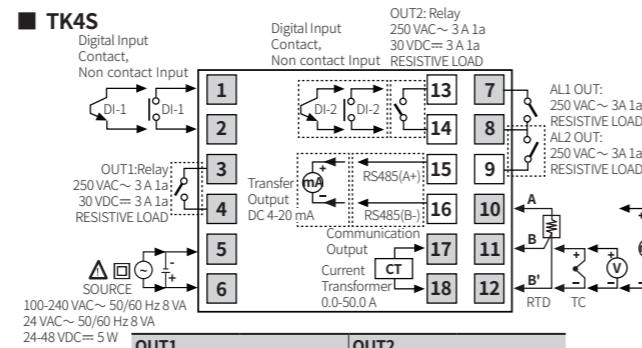
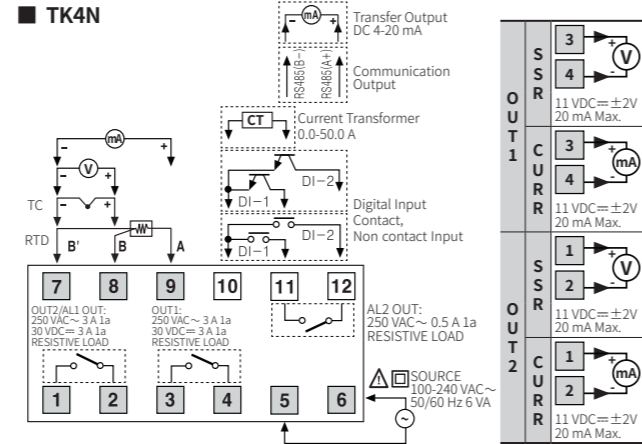

OUT1		OUT2	
SSR	Current	SSR	Current
3	11 VDC=±2V 20 mA Max.	13	11 VDC=±2V 20 mA Max.
4	DC 0/4-20 mA Load 500 Ω Max.	14	DC 0/4-20 mA Load 500 Ω Max.

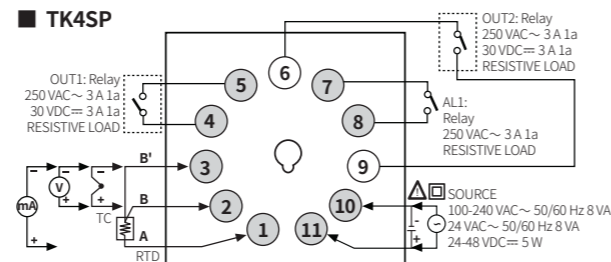

OUT1		OUT2	
SSR	Current	SSR	Current
5	11 VDC=±2V 20 mA Max.	6	11 VDC=±2V 20 mA Max.
4	DC 0/4-20 mA Load 500 Ω Max.	9	DC 0/4-20 mA Load 500 Ω Max.

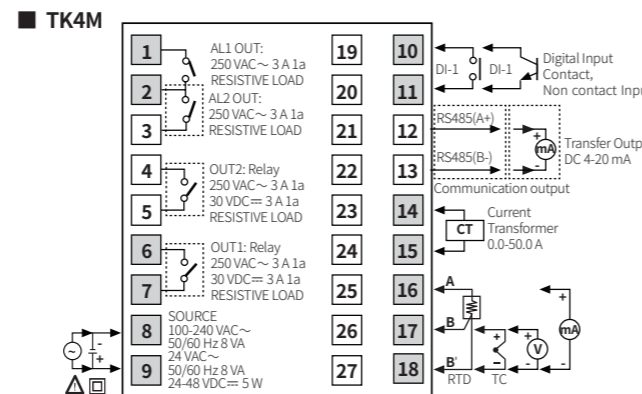

OUT1		OUT2	
SSR	Current	SSR	Current
6	11 VDC=±2V 20 mA Max.	4	11 VDC=±2V 20 mA Max.
7	DC 0/4-20 mA Load 500 Ω Max.	5	DC 0/4-20 mA Load 500 Ω Max.

TK4H / W / L

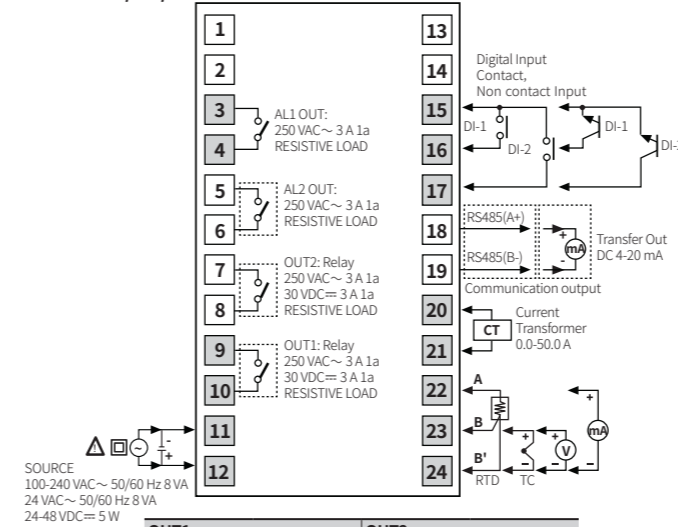

OUT1		OUT2	
SSR	Current	SSR	Current
9	11 VDC=±2V 20 mA Max.	7	11 VDC=±2V 20 mA Max.
10	DC 0/4-20 mA Load 500 Ω Max.	8	DC 0/4-20 mA Load 500 Ω Max.

Crimp Terminal Specifications

- Unit: mm, Use the crimp terminal of follow shape.

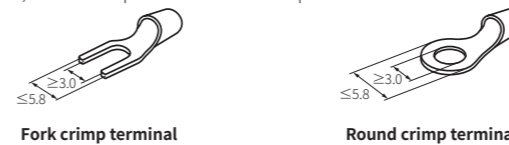

Initial Display When Power is ON

When power is supplied, after all display will flash for 1 sec, model name is displayed sequentially. After input sensor type will flash twice, enter into RUN mode.

	1. All display	2. Model	3. Input specification	4. Run mode
PV display part	8.8.8.8	EE4	EE4	oPE n
SV display part	8.8.8.8	14r n	EE4H	0

Mode Setting

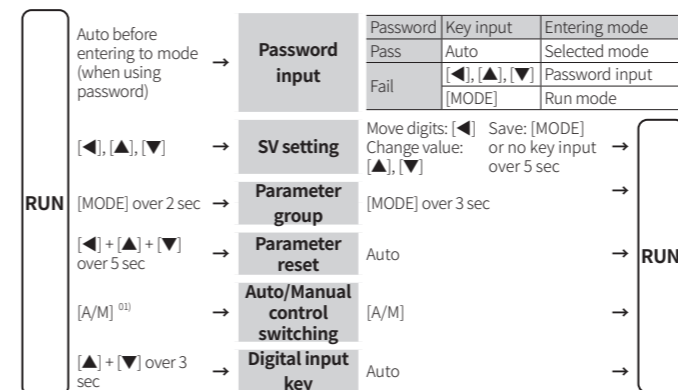

01) In case of TK4N / 4S / 4SP model, short press of [MODE] key replaces [A/M] key function.

Parameter Setting

- Some parameters are activated/deactivated depending on the model or setting of other parameters.
- The 'Parameter mask' feature, which hide unnecessary or inactive parameters, and the 'User parameter group' feature, which quickly and easily set up certain parameters that are frequently used, can be set up in DAQMaster.
- Refer to the user manual for the details.

Parameter 1 group

Parameter	Display	Default
Control output RUN/STOP	r - 5	r U n
Multi SV selection	5 u - n	5 u - 0
Heater current monitoring	C t - A	0 0
Alarm output1 low limit	AL L L	1 5 5 0
Alarm output1 high limit	AL L H	1 5 5 0
Alarm output2 low limit	AL 2 L	1 5 5 0
Alarm output2 high limit	AL 2 H	1 5 5 0
Alarm output3 low limit	AL 3 L	1 5 5 0
Alarm output3 high limit	AL 3 H	1 5 5 0
Multi SV 0	5 u - 0	0 0 0 0
Multi SV 1	5 u - 1	0 0 0 0
Multi SV 2	5 u - 2	0 0 0 0
Multi SV 3	5 u - 3	0 0 0 0

Parameter 4 group

Parameter	Display	Default
Alarm output1 Operation mode	AL - 1	d u C C
Alarm output1 Option	AL L t	AL - A
Alarm output1 Hysteresis	AL H Y	0 0 1
Alarm output1 contact type	A L n	n o
Alarm output1 ON delay time	A L o n	0 0 0 0
Alarm output1 OFF delay time	A L o F	0 0 0 0
Alarm output2 Operation mode	AL - 2	J J d u
Alarm output2 Option	AL 2 t	AL - A
Alarm output2 Hysteresis	AL 2 Y	0 0 1
Alarm output2 contact type	A 2 n	n o
Alarm output2 ON delay time	A 2 o n	0 0 0 0
Alarm output2 OFF delay time	A 2 o F	0 0 0 0
Alarm output3 Operation mode	AL - 3	o F F
Alarm output3 Option	AL 3 t	AL - A
Alarm output3 Hysteresis	AL 3 Y	0 0 1
Alarm output3 contact type	A 3 n	n o
Alarm output3 ON delay time	A 3 o n	0 0 0 0
Alarm output3 OFF delay time	A 3 o F	0 0 0 0
LBA time	L b A t	0 0 0 0
LBA band	L b A b	0 0 2 (0 0 3)
Analog Transmission output1 Mode	A o n 1	P u
Transmission output1 low limit	F 5 L 1	- 2 0 0
Transmission output1 high limit	F 5 H 1	1 3 5 0
Analog Transmission output2 Mode	A o n 2	P u
Transmission output2 low limit	F 5 L 2	- 2 0 0
Transmission output2 high limit	F 5 H 2	1 3 5 0
Communication address	A d r 5	0 1
Communication speed	B P 5	9 6
Comm. parity bit	P r t y	n o n E
Comm. stop bit	S t P	2
Response time	r 5 t	2 0
Comm. write	C o n W	E n A

Parameter 2 group

Parameter	Display	Default
Auto tuning RUN/STOP	A t	o F F
Heating proportional band	H - P	0 1 0 0
Cooling proportional band	C - P	0 1 0 0
Heating integral time	H - I	0 0 0 0
Cooling integral time	C - I	0 0 0 0
Heating derivative time	H - d	0 0 0 0
Cooling derivative time	C - d	0 0 0 0
Dead overlap band	d b	0 0 0 0
Manual reset	r E 5 t	0 5 0 0
Heating hysteresis	H H Y 5	0 0 2
Heating OFF offset	H o 5 t	0 0 0
Cooling hysteresis	C H Y 5	0 0 2
Cooling OFF offset	C o 5 t	0 0 0
MV low limit	L - n u	+ 0 0 0
MV high limit	H - n u	1 0 0 0
RAMP up change rate	r A n u F	0 0 0
RAMP down change rate	r A n d	0 0 0
RAMP time unit	r A n t	n i n

Parameter 3 group

Parameter	Display	Default
Input specification	i n - t	EE4H
Temperature unit	U n i t	o C
Analog low limit	L - r 0	0 0 0 0
Analog high limit	H - r 0	1 0 0 0
Scaling decimal point	d o t	0 0
Low limit scale	L - 5 C	0 0 0 0
High limit scale	H - 5 C	1 0 0 0
Display unit	d U n t	o r o
Input correction	i n - b	0 0 0 0
Input digital filter	n A u F	0 0 0 1
SV low limit	L - 5 u	- 2 0 0
SV high limit	H - 5 u	1 3 5 0

Parameter 5 group

Parameter	Display	Default
Multi SV number	n E 5 u	1
Digital input key	d i - E	5 t o P
Digital input1 Terminal Function	d i - 1	o F F
Digital input2 Terminal Function	d i - 2	o F F
Manual control, initial MV	i E n u	A U t o
Manual control, preset	P r n u	0 0 0 0
Sensor error MV	E r n u	0 0 0 0
Control stop MV	S t n u	0 0 0 0
Control stop alarm output	S t A L	C o n t
User level	U 5 E r	5 t n d
SV setting lock	L C 5 u	o F F
Parameter 1 group lock	L C P 1	o F F
Parameter 2 group lock	L C P 2	o F F
Parameter 3 group lock	L C P 3	o F F
Parameter 4 group lock	L C P 4	o F F
Parameter 5 group lock	L C P 5	o F F
Password setting	P W d	0 0 0 0